

**TORREXX**  
the power of innovation



**NEW!**

## The Next Generation of Electric Vaporizers

Set your mind at ease and deliver the reliability of LP-Gas that your customer expects with Algas-SDI's latest electric vaporizer—the **TORREXX**! Designed with the discriminating LP-Gas professional and end-user in mind, the **TORREXX** raises the bar in performance, safety, and reliability.

### INNOVATIONS:

- Proprietary Liqui-SAFE Valve™ positively prevents liquid carry-over and provides visual indication when tripped.
- Greater reliability through simplified and more robust controls - no start/stop switches.
- Heavy Duty 135 amp contactor increases life span of contactor and reduces maintenance.
- Replaceable temperature controller with an adjustable set point.
- Thermocouple temperature sensor increases life and reduces maintenance.
- Modular control board with easily replaceable components.

### HALLMARK FEATURES:

- Hazardous area classification - Class I, Division 1, and Zone 1.
- Dry electric design requires no water or glycol.
- 98% Thermal Efficiency.
- Operates on any LPG mixture from 100% propane to 100% butane.
- Perfect for any climate - rated to -40 F./-40 C.
- Ready for operation in less than one minute.
- Automatic restart standard on all units.



- **SAFE**
- **DURABLE**
- **SIMPLE**
- **LOW MAINTENANCE**
- **RELIABLE**

# TORREXX

the power of innovation

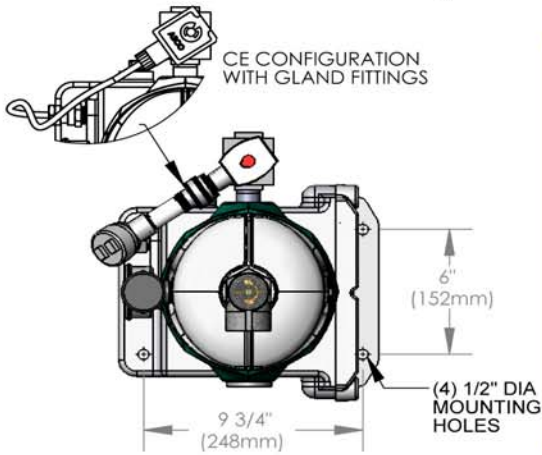

MODEL	TX25	TX50	TX100	TX160	TX240	TX320
MMBtu	1.1	2.2	4.5	7.2	10.9	14.5
Kg/Hr	25	50	100	160	240	320
Gal/Hr (Nominal)	12.5	25	50	80	120	160
A		45.40" 1153mm		51.40" 1306mm	56.40" 1433mm	63.40" 1610mm
B		41" 1040mm		47" 1190mm	52" 1320mm	59" 1500mm

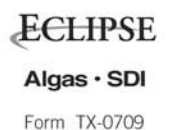
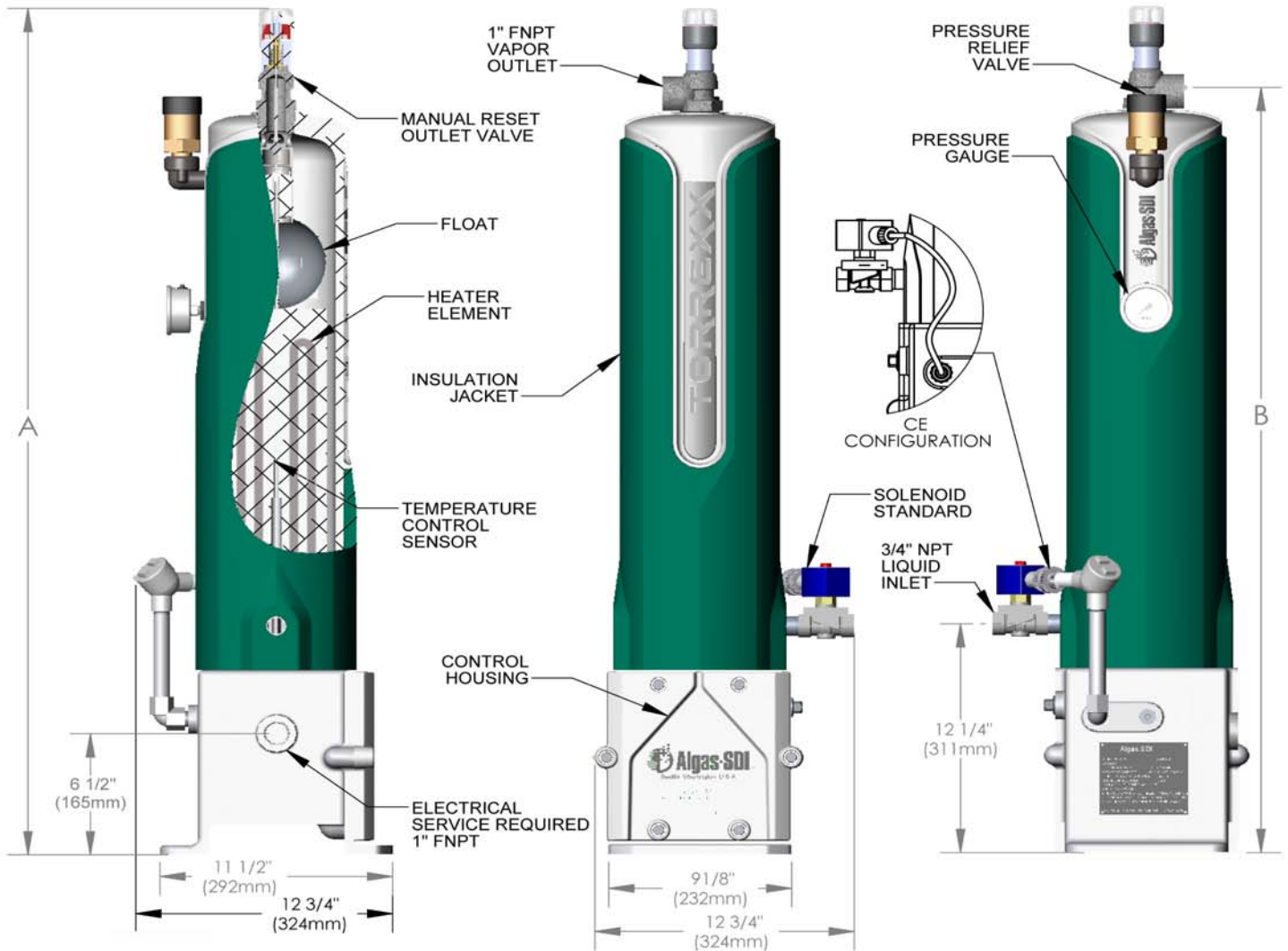



**Power Equipment Company  
Manufacturers' Representative & Distributor  
2011 Williamsburg Road  
Richmond, Virginia 23231  
T: 804-236-3800  
F: 804-236-3882  
[sales@peconet.com](mailto:sales@peconet.com)  
[www.peconet.com](http://www.peconet.com)**